

Fibre Channel - MIL-STD-1553
ARINC429 - ARINC664 - AFDX
MIL-STD-1760 - STANAG3910/EFEX

ARINC429

Specification Tutorial

AIM-USA
3703 N. 200th St.
Elkhorn, NE 68022

Phone: 866-AIM-1553
Fax: 402-763-9645

salesusa@aim-online.com
www.aim-online.com

July 2005
V1.1A



Avionics Test and Simulation
Interface Modules



www.aim-online.com

Right on Target

ARINC429

Specification Tutorial

V1.1 Rev. A

July 2005

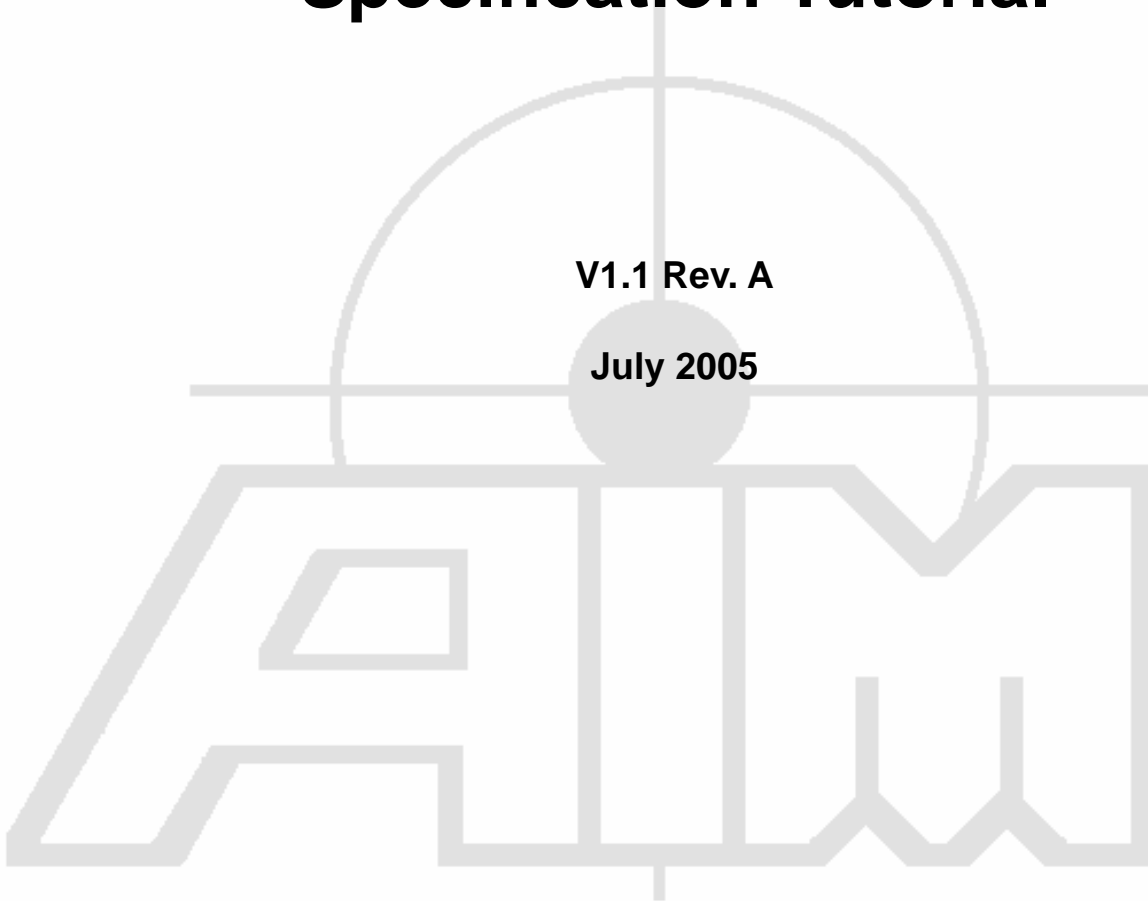



www.aim-online.com

AIM WORLDWIDE

AIM-USA

3703 North 200th Street
Elkhorn, NE 68022
866-AIM-1553
866-AIM-A429
salesusa@aim-online.com

AIM GmbH

Sasbacher Str. 2
79111 Freiburg, Germany
+49-761-45 22 90
sales@aim-online.com

Munich Sales Office

Terofalstrasse 23 a
80689 Muenchen
+49-89-70 92 92 92
salesgermany@aim-online.com

AIM UK

Cressex Business Park
Lincoln Rd, High Wycombe
Bucks HP12 3RB, England
+44-1494-44 68 44
salesuk@aim-online.com

Notice: The information that is provided in this document is believed to be accurate. No responsibility is assumed by AIM for its use. No license or rights are granted by implication in connection therewith. Specifications are subject to change without notice.

© Copyright 2005: AIM



DOCUMENT HISTORY

Version	Cover Date	Created by	Description
1.0	July 2001	Pat Frodyma	Creation of document
1.1	Dec 2001	Pat Frodyma	Edits
1.1A	July 2005	J. Furgerson	Document restucture



THIS PAGE INTENTIONALLY LEFT BLANK



TABLE OF CONTENTS

Title	Page
About this Manual.....	1
ARINC429 Specification Overview	3
Overview of ARINC.....	3
History of ARINC429.....	4
The ARINC429 Specification.....	5
Cable Characteristics.....	6
Transmission Characteristics.....	7
Waveform Parameters.....	8
Word Formats	9
Parity.....	9
Sign/Status Matrix	9
Data.....	11
Data Types.....	12
Source/Destination Identifier	13
Label	14
Attachments to the ARINC429 Specification	15
ARINC Contact Information	17



THIS PAGE INTENTIONALLY LEFT BLANK



ABOUT THIS MANUAL

This manual was developed to provide a general overview of the ARINC429 Specification, its characteristics and applications. The ARINC429 Specification is a copy written document owned by Aeronautical Radio, Inc. who is responsible for its modification and distribution.

This manual refers predominately to Part 1 of the 429 Specification outlining the functional description, electrical characteristics and word formats. Complete and current copies of the Specification can be obtained from Aeronautical Radio, Inc. Contact information is made available on page 18 of this manual.

AIM provides Commercial-Off-The-Shelf (COTS) products to design, produce, integrate, test and troubleshoot all systems and capabilities mentioned in this ARINC429 Tutorial Manual.

AIM software products also support full Remote Terminal production testing, full bus analysis and complete system emulation and test capabilities per ARINC429 specifications.

AIM is also a leading designer and manufacturer of other high performance test and simulation modules, databus analyzer software and systems for MIL-STD-1553 A/B, STANAG3910, MIL-STD-1760 Applications, AFDX/ARINC664, PANA VIA Serial Link and Fibre Channel. Supported hardware platforms include PC/AT, PCI, Compact PCI, VME, VXI, PMC, and PCMCIA. Information about all AIM products can be found at <http://www.aim-online.com>.



THIS PAGE INTENTIONALLY LEFT BLANK

ARINC429 SPECIFICATION OVERVIEW

The ARINC429 Specification defines the standard requirements for the transfer of digital data between avionics systems on commercial aircraft. ARINC429 is also known as the Mark 33 DITS Specification. Signal levels, timing and protocol characteristics are defined for ease of design implementation and data communications on the Mark 33 Digital Information Transfer System (DITS) bus.

ARINC429 is a privately copywritten specification developed to provide interchangeability and interoperability of line replaceable units (LRUs) in commercial aircraft. Manufacturers of avionics equipment are under no requirement to comply to the ARINC429 Specification, but designing avionics systems to meet the design guidelines provides cross-manufacturer interoperability between functional units.

OVERVIEW OF ARINC

ARINC stands for Aeronautical Radio, Inc., a private corporation organized in 1929, and is comprised of airlines, aircraft manufacturers and avionics equipment manufacturers as corporate shareholders. ARINC was developed to produce specifications and standards for avionics equipment outside the government for domestic and overseas manufacturers.

ARINC copywrites and publishes standards produced by the Airlines Electronic Engineering Committee (AEEC). The AEEC is an international standards organization made up of major airline operators, avionics industry manufacturers and ARINC members.

The AEEC sets standards for avionics equipment and systems and provides industry defined requirements for standardization of form, fit and function between various manufacturers products.

ARINC publishes the AEEC produced standards under three types of documents:

1. ARINC Characteristics

Characteristics are definitions of the form, fit and function of avionics equipment. These documents are equipment specific and define how a unit will operate. The ARINC 500 Series of Characteristics define older analog avionics equipment where the ARINC 700 Series are more current documents and are typically digital versions of the analog specs.

400 Series documents are general design and support documentation for the 500 Series avionics equipment characteristics.

600 Series documents are general design and support documentation for the 700 Series avionics equipment characteristics.



2. ARINC Specifications

Specifications are used to define

- ⊕ Physical packaging and mounting of avionics equipment
- ⊕ Data communications standards
- ⊕ High level computer languages

The ARINC429 Specification, Mark 33 Digital Information Transfer System falls under the Specification document category.

3. ARINC Reports

Reports provide general information and best practice guidelines for airlines. Reports predominately refer to maintenance and support procedures.

HISTORY OF ARINC429

The ARINC429 Specification developed out of the original commercial aviation digital communication spec, the ARINC 419 Specification. The ARINC 419, first released in 1966 and last revised in 1983, describes four different wiring topologies, including a serial, twisted shielded pair interface used by the Digital Air Data System (DADS), known as the ARINC 575 or DADS 575 Spec.

This serial topology evolved into the ARINC429 Specification, first released as ARINC429-1 in April 1978, and currently exists as ARINC429-15. ARINC429-15 was adopted by the AEEC in 1995 and is comprised of 3 parts:

- ⊕ **ARINC Specification 429, Part 1-15:** Functional Description, Electrical Interface, Label Assignments and Word Formats
- ⊕ **ARINC Specification 429, Part 2-15:** Discrete Word Data Standards
- ⊕ **ARINC Specification 429, Part 3-15:** File Data Transfer Techniques

Part 1 addresses the buses physical parameters, label and address assignments, and word formats.

Part 2 defines the formats of words with discrete word bit assignments.

Part 3 defines link layer file data transfer protocol for data block and file transfers.

THE ARINC429 SPECIFICATION

The ARINC429 Specification establishes how avionics equipment and systems communicate on commercial aircraft. The specification defines electrical characteristics, word structures and protocol necessary to establish bus communication. ARINC429 utilizes the simplex, twisted shielded pair data bus standard Mark 33 Digital Information Transfer System bus.

ARINC429 defines both the hardware and data formats required for bus transmission. Hardware consists of a single transmitter – or source – connected to from 1-20 receivers – or sinks – on one twisted wire pair. Data can be transmitted in one direction only – simplex communication – with bi-directional transmission requiring two channels or buses. The devices, line replaceable units or LRUs, are most commonly configured in a star or bus-drop topology. Each LRU may contain multiple transmitters and receivers communicating on different buses. This simple architecture, almost point-to-point wiring, provides a highly reliable transfer of data.

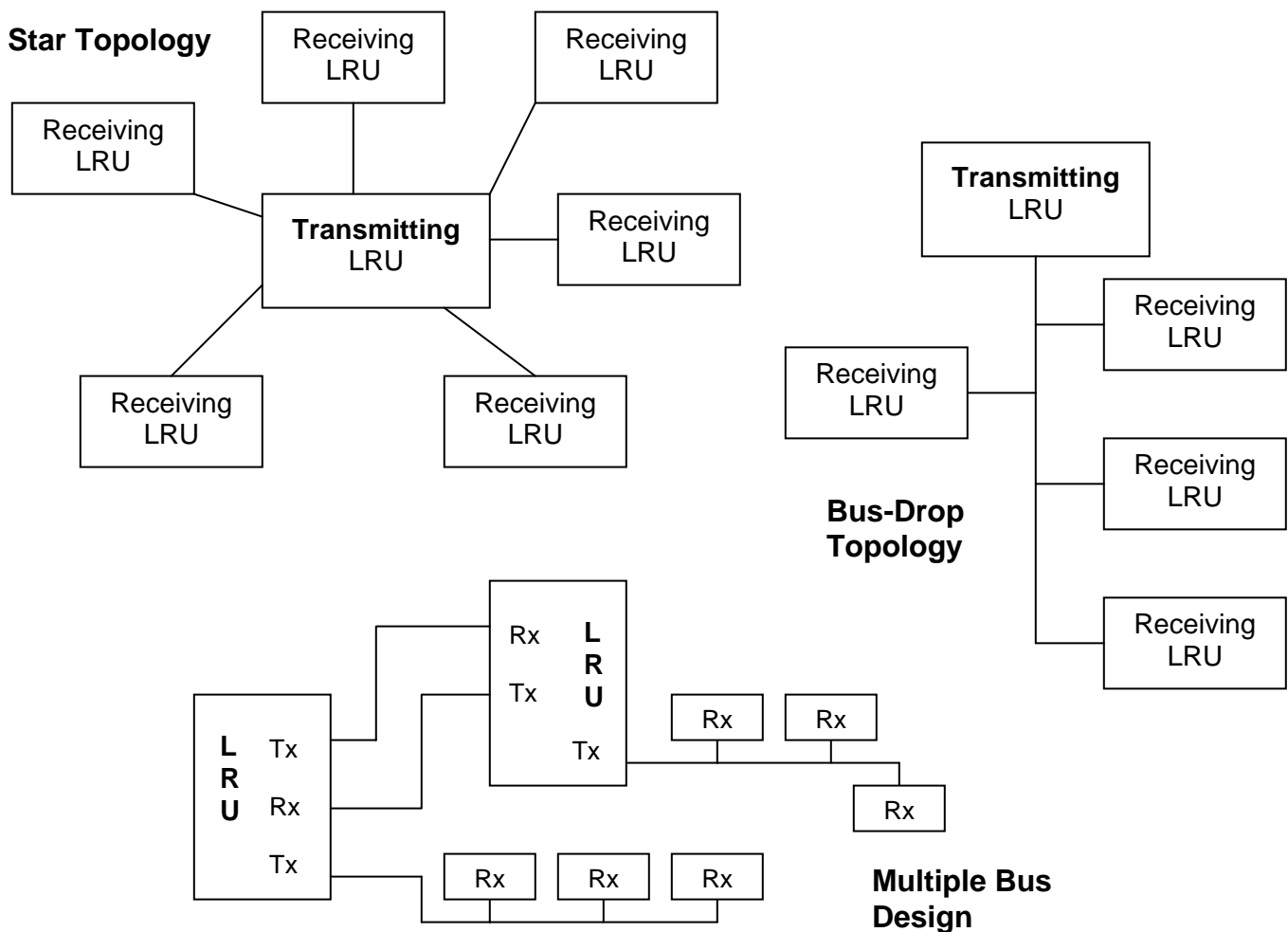



A transmitter may 'talk only' to a number of receivers on the bus, up to 20 on one wire pair, with each receiver continually monitoring for its applicable data, but does not acknowledge receipt of the data.

A transmitter may require acknowledgement from a receiver when large amounts of data have been transferred. This handshaking is performed using a particular word style, as opposed to a hard wired handshake. When this two way communication format is required, two twisted pairs constituting two channels are necessary to carry information back and forth, one for each direction.

Transmission from the source LRU is comprised of 32 bit words containing a 24 bit data portion containing the actual information, and an 8 bit label describing the data itself. LRUs have no address assigned through ARINC429, but rather have Equipment ID numbers which allow grouping equipment into systems, which facilitates system management and file transfers.

Sequential words are separated by at least 4 bit times of null or zero voltage. By utilizing this null gap between words, a separate clock signal is unnecessary. Transmission rates may be at either a low speed – 12.5 kHz – or a high speed – 100kHz.

CABLE CHARACTERISTICS

The transmission bus media uses a 78Ω shielded twisted pair cable. The shield must be grounded at each end and at all junctions along the bus.

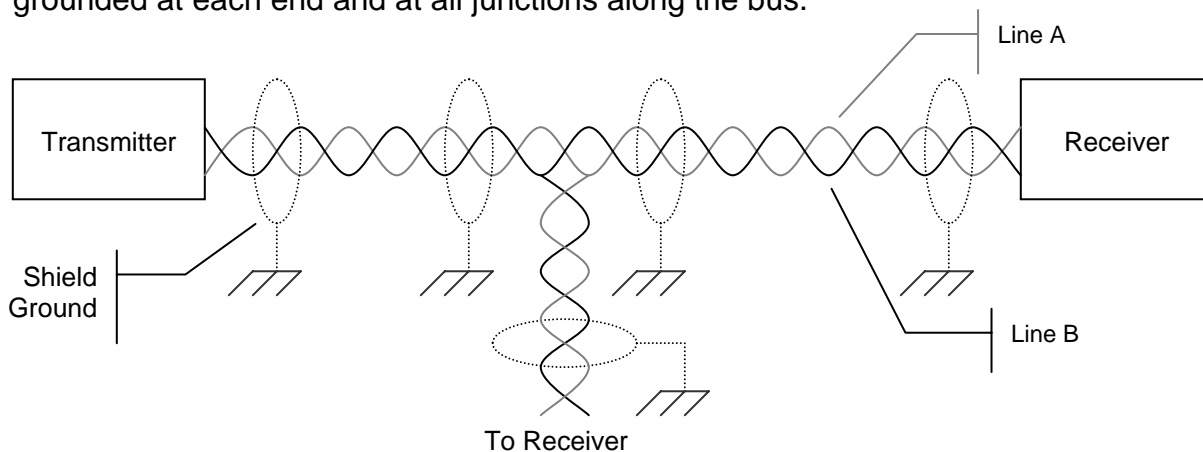

The transmitting source output impedance should be $75 \Omega \pm 5 \Omega$ divided equally between Line A and Line B. This balanced output should closely match the impedance of the cable. The receiving sink must have an effective input impedance of $8k \Omega$ minimum.

Maximum length is not specified, as it is dependent on the number of sink receivers, sink drain and source power. Most systems are designed for under 150 feet, but conditions permitting, can extend to 300 feet and beyond.

TRANSMISSION CHARACTERISTICS

ARINC429 specifies two speeds for data transmission. Low speed operation is stated at 12.5 kHz, with an actual allowable range of 12 to 14.5 kHz. High speed operation is 100 kHz $\pm 1\%$ allowed. These two data rates can not be used on the same transmission bus.

Data is transmitted in a bipolar, Return-to-Zero format. This is a tri-state modulation consisting of HIGH, NULL and LOW states.

Transmission voltages are measured across the output terminals of the source. Voltages presented across the receiver input will be dependent on line length, stub configuration and the number of receivers connected. The following voltage levels indicate the three allowable states:

TRANSMIT	STATE	RECEIVE
+10.0 V \pm 1.0 V	HIGH	+6.5 to 13 V
0 V \pm 0.5V	NULL	+2.5 to -2.5 V
-10.0 V \pm 1.0 V	LOW	-6.5 to -13 V

In bipolar, Return-to-Zero – or RZ – format, a HIGH (or 1) is achieved with the transmission signal going from NULL to +10 V for the first half of the bit cycle, then returning to zero or NULL.

A LOW (or 0) is produced by the signal dropping from NULL to –10 V for the first half bit cycle, then returning to zero.

With a Return-to-Zero modulation format, each bit cycle time ends with the signal level at 0 Volts, eliminating the need for an external clock, creating a self-clocking signal.

An example of the bipolar, tri-state RZ signal is shown here:

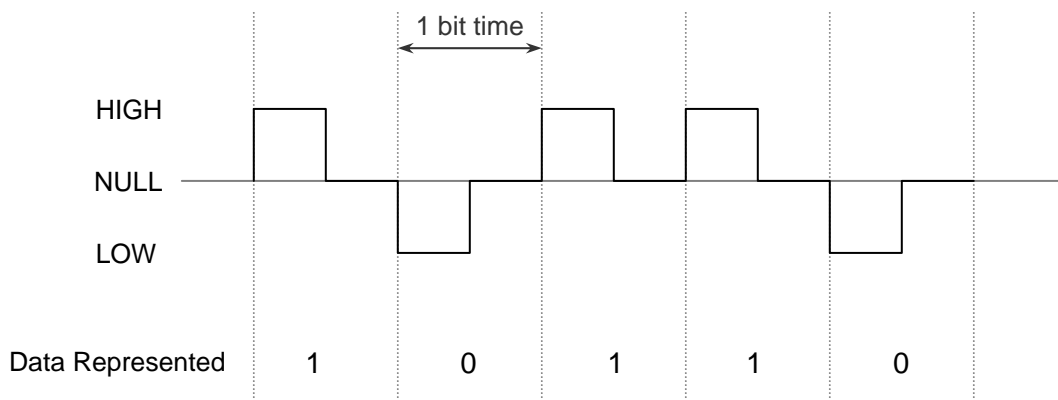



WAVEFORM PARAMETERS

Pulse rise and fall times are controlled by RC circuits built into ARINC429 transmitters. This circuitry minimizes overshoot ringing common with short rise times. Allowable rise and fall times are shown below for both bit rates. Bit and 1/2 bit times are also defined.

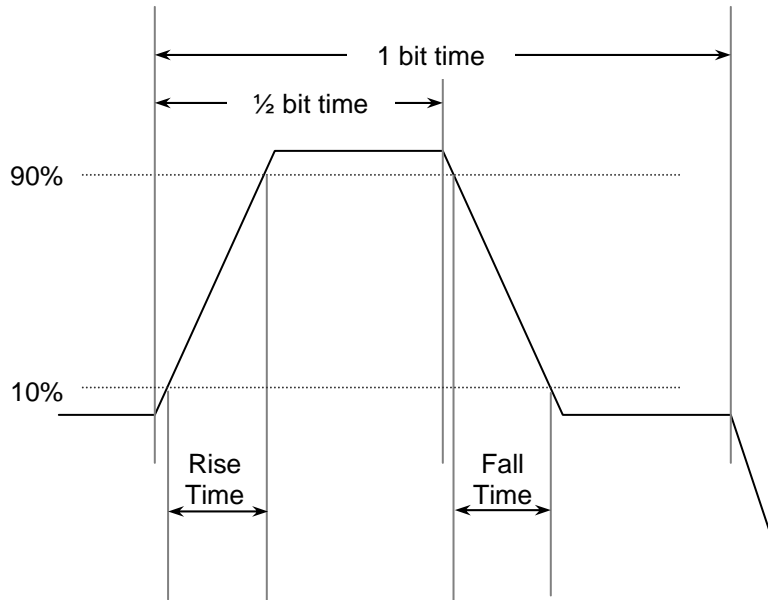

	High Speed	Low Speed
Bit Rate	100 kbps \pm 1%	12 – 14.5 kbps \pm 1%
1 bit time	10 μ sec \pm 2.5%	(1/Bit rate) μ sec \pm 2.5%
1/2 bit time	5 μ sec \pm 5%	(1 bit time/2) \pm 5%
Rise Time	1.5 μ sec \pm 0.5 μ sec	10 μ sec \pm 5 μ sec
Fall Time	1.5 μ sec \pm 0.5 μ sec	10 μ sec \pm 5 μ sec

WORD FORMATS

ARINC429 protocol uses a point-to-point format, transmitting data from a single source on the bus to up to 20 receivers. The transmitter is always transmitting, either data words or the NULL state. Most ARINC messages contain only one data word consisting of either Binary (BNR), Binary Coded Decimal (BCD) or alphanumeric data encoded using ISO Alphabet No. 5. File data transfers that send more than one word are also allowed.

ARINC429 data words are 32 bit words made up of five primary fields:

- ⊕ Parity – 1 bit
- ⊕ Sign/Status Matrix (SSM) – 2 bits
- ⊕ Data – 19 bits
- ⊕ Source/Destination Identifier (SDI) – 2 bits
- ⊕ Label – 8 bits

MSB																																LSB								
32	31	30	29	28	27	26	25	24	23	22	21	20	19	18	17	16	15	14	13	12	11	10	9	8	7	6	5	4	3	2	1									
P	SSM		MSB													Data													LSB		SDI		Label							

ARINC429 32 bit Word Format

The only two fields definitively required are the Label and the Parity bit, leaving up to 23 bits available for higher resolution data representation. Many non-standard word formats have been adopted by various manufacturers of avionics equipment. Even with the variations included, all ARINC data is transmitted in 32 bit words. Any unused bits are padded with zeros.

Parity

ARINC429 defines the Most Significant Bit (MSB) of the data word as the Parity bit. ARINC uses odd parity as an error check to insure accurate data reception. The number of Logic 1s transmitted in each word is an odd number, with bit 32 being set or cleared to obtain the odd count. ARINC429 specifies no means of error correction, only error detection.

Sign/Status Matrix

Bits 31-30 are assigned as the Sign/Status Matrix field or SSM. Depending on the words Label, which indicates which type of data is being transmitted, the SSM field can provide different information. (See page 15 for more information on data types.) This field can be used to indicate sign or direction of the words data, or report source equipment operating status and is dependant on the data type.



For Binary Coded Decimal data – **BCD** – the

SSM can be used to indicate the sign or direction of the data contained in the ARINC word.

Use of the sign function for BCD data is optional. If not used, the SSM bits should be padded – set to zero.

The No Computed Data code (01) is used to identify a source system that is not able to produce reliable data.

The Functional Test code (10) is transmitted with an instruction command to perform a functional test on the receiving unit. When the Functional Test code is received back from the sink, it identifies the data content of the word as containing the results of the test.

When the Label indicates Binary data – **BNR** – bits 31-30 are used to indicate source equipment operating status as shown here.

The Failure Warning code (00) indicates a source system failure that could produce an unreliable data output.

The No Computed Data code (01) indicates unreliable data output caused by a condition other than a system failure (which is indicated by using the Failure Warning code).

The Functional Test code (10) is used to indicate the word's data contains the results of the functional test.

The use of the Sign function is optional with BNR data and if used, is represented by bit 29.

When the Label indicates **Discrete Data** words, bits 31-30 are utilized to report source equipment status using the encoding shown here.

BCD data SSM Sign Coding

BIT		Decoded Information
31	30	
0	0	Plus, North, East, Right, To, Above
0	1	No Computed Data
1	0	Functional Test
1	1	Minus, South, West, Left, From, Below

BNR data SSM Status Coding

BIT		Decoded Information
31	30	
0	0	Failure Warning
0	1	No Computed Data
1	0	Functional Test
1	1	Normal Operation

BNR data SSM Sign Coding

BIT		Decoded Information
29		
0		Plus, North, East, Right, To, Above
1		Minus, South, West, Left, From, Below

Discrete data SSM Status Coding

BIT		Decoded Information
31	30	
0	0	Verified Data, Normal Operation
0	1	No Computed Data
1	0	Functional Test
1	1	Failure Warning

Data

ARINC429 defines bits 11-29 as those containing the word's data information. Formatting of the data bits, indeed the entire ARINC429 word, is very flexible.

When transmitting data words on the ARINC bus, the Label is transmitted first, MSB first, followed by the rest of the bit field, LSB first. Bit transmission order looks like this:

MSB											LSB																									
32	31	30	29	28	27	26	25	24	23	22	21	20	19	18	17	16	15	14	13	12	11	10	9	8	7	6	5	4	3	2	1					
P	SSM	MSB											Data											LSB	SDI	Label										

ARINC429 32 bit Word Format

8	7	6	5	4	3	2	1	9	10	11	12	13	14	15	16	17	18	19	20	21	22	23	24	25	26	27	28	29	30	31	32		
Label								SDI	LSB											Data											MSB	SSM	P

ARINC429 Word Transfer Order

The Label is always transmitted first, in reverse order to rest of the ARINC word – a compensation for compatibility with legacy systems. The receiving LRU is responsible for data translation and regrouping of bits into proper order.

Data types available in ARINC429 are:

- ⊕ Binary – BNR – Transmitted in fractional two's complement notation
- ⊕ Binary Coded Decimal – BCD – Numerical subset of ISO Alphabet No. 5
- ⊕ Discrete Data – Combination of BNR, BCD or individual bit representation
- ⊕ Maintenance Data and Acknowledgement – Requires two-way communication
- ⊕ Williamsburg/Buckhorn Protocol – A bit-oriented protocol for file transfers



Data Types

BNR Data

Binary, or BNR, encoding stores data as a binary number. Bit 29 is utilized as the sign bit with a 1 indicating a negative number – or South, West, Left, From or Below. Bit 28 is then the data's Most Significant Bit (MSB), or $\frac{1}{2}$ of the maximum value of the defined parameters scale factor. Bit 27 is $\frac{1}{2}$ the value of Bit 28 or $\frac{1}{4}$ of the scale factor. Bit 26 is $\frac{1}{2}$ the value of Bit 27 or $\frac{1}{8}$ the scale factor and so on.

32	31	30	29	28	27	26	25	24	23	22	21	20	19	18	17	16	15	14	13	12	11	10	9	8	7	6	5	4	3	2	1
P	SSM	MSB		Data														LSB		SDI	Label										

ARINC429 BNR Word Format

BCD Data

Binary Coded Decimal, or BCD format uses 4 data field bits to represent each decimal digit. Up to 5 subfields can be utilized to provide 5 binary values, with the Most Significant subfield containing only 3 data field bits (for a maximum binary value of 7). If the Most Significant digit is greater than 7, bits 27-29 are padded with zeros and the second subfield becomes the Most Significant digit allowing 4 binary values instead of 5 to be represented. The SSM field is used to provide the sign of the value.

32	31	30	29	28	27	26	25	24	23	22	21	20	19	18	17	16	15	14	13	12	11	10	9	8	7	6	5	4	3	2	1
P	SSM	Digit 1			Digit 2			Digit 3			Digit 4			Digit 5			SDI	Label													

ARINC429 BCD Word Format

Discrete Data

Discrete data can be made up of BNR and/or BCD data, or as individual bits representing specific equipment conditions. Pass/Fail, Activated/Non-Activated and True/False conditions relating to system or subsystem operational activity can be represented by setting or clearing predefined bits in the word data field.

Maintenance Data and Acknowledgement

Maintenance Data and Acknowledgement implies duplex or two-way communication between source and sink. Since ARINC429 only provides for one-way simplex transmission, two ARINC channels are required for an LRU to send and receive data. Maintenance messages typically require exchanging a sequence of messages and often utilize a bit oriented protocol such as the Williamsburg/Buckhorn protocol.

Williamsburg/Buckhorn Protocol

Williamsburg/Buckhorn is a bit-oriented protocol used to transmit files across an ARINC bus. Williamsburg has superseded the former AIM data (Acknowledge, ISO Alphabet No. 5 and Maintenance data) file transfer methods which were applicable in earlier versions of ARINC429. File transfers are necessary when more than 21 bits of data are required to be transmitted.

When initializing a file transfer with the bit-oriented protocol, source and sink units need to first establish a handshake to determine a common protocol both can use. The source initiates communication with predefined codes to determine compatibility with receiving units. A Request to Send word (RTS) is transmitted containing a destination code and word count. The receiver responds with a Clear to Send word (CTS), retransmitting back the destination and word count information to insure accuracy. Upon confirmed reception of the CTS data, the source begins the file transfer.

Files are transferred in Link Data Units – LDUs – which are blocks of words from 3 to 255 words in length. File transfers begin with a Start of Transmission word (SOT) which includes a file sequence number, a General Format Identifier (GFI) and a LDU Sequence Number. After the SOT, the data words are sent, followed by an End of Transmission word (EOT). The EOT includes a CRC and the LDUs position in the file being sent. The receiving unit verifies the EOT word and responds with an Acknowledgement word (ACK). If additional LDUs are required to complete the file transfer, the source sends a new RTS word to reinitialize the process.

Source/Destination Identifier

The Source/Destination Identifier – SDI – utilizes bits 9-10 and is optional under the ARINC429 Specification. The SDI can be used to identify which source is transmitting the data or by multiple receivers to identify which receiver the data is meant for.

For higher resolution data, bits 9-10 may be used instead of using them as an SDI field. When used as an Identifier, the SDI is interpreted as an extension to the word Label.



Label

Bits 1-8 contain the ARINC label known as the Information Identifier. The Label is expressed as a 3 digit octal number with receivers programmed to accept up to 255 Labels. The Label's Most Significant Bit resides in the ARINC word's Least Significant Bit location.

	LSB						MSB	
BIT	8	7	6	5	4	3	2	1
Octal Value	4	2	1	4	2	1	2	1

The Label is used to identify the word's data type (BNR, BCD, Discrete, etc) and can contain instructions or data reporting information. Labels may be further refined by utilizing the first 3 bits of the data field, Bits 11-13, as an Equipment Identifier to identify the bus transmission source. Equipment IDs are expressed in hexadecimal values.

For example, BNR Label 102 is Selected Altitude. This data can be received from the Flight Management Computer (Equipment ID 002_{Hex}), the DFS System (Equipment ID 020_{Hex}) or the FCC Controller (Equipment ID 0A1_{Hex}).

The Label is always sent first in an ARINC transmission and is a required field, as is the Parity bit. Labels are transmitted MSB first, followed by the rest of the ARINC word, transmitted LSB first.

ATTACHMENTS TO THE ARINC429 SPECIFICATION

The ARINC429 Specification, as adopted by the AEEC and published by ARINC, contains multiple Attachments, Appendices and Supplements. A listing of Attachments and Appendices with brief description of each attachment follows.

Attachment 1 – Label Codes & Equipment Codes

Contains Aircraft Parameters with their associated Octal Code No., Hex Equipment ID, the Binary Label and the Data Word type.

Attachment 2 – Data Standards

A table containing Aircraft Parameters with Units and Range (Scale) defined, number of Significant bits, Resolution, Min/Max Transit Intervals and Max Transport Delay. Separate tables exist for BCD and BNR Data

Attachment 3 – Voltage Levels

Graphic representation of Transmitter Output and Receiver Input Voltage Levels.

Attachment 4 – Input/Output Circuit Standards

Electrical characteristics of receiver and transmitter.

Attachment 5 – ISO Code #5

Table showing the ISO Alphabet #5 encoding.

Attachment 6 – General Word Formats and Encoding Examples

Word layouts showing bit assignments for general word formats for all data types and includes multiple examples of specific word layouts.

Attachment 7 – Data Bit Encoding Logic

Graphical representation of a Return to Zero (RZ) waveform.

Attachment 8 – Output Signal Timing Tolerances

Graph showing and defining Waveform characteristics for high and slow speed signals.



Attachment 9A – General Aviation Labels and Data Standards

Labels and data standards as assigned by GAMA (General Aviation and Manufacturers Association). These data standards are made available since the general aviation community commonly uses them.

Attachment 9B – General Aviation Word Examples

Examples of word layouts as assigned by GAMA.

Attachment 9c – General Aviation Equipment Identifiers

Equipment ID numbers as assigned by GAMA.

Attachment 10 – Manufacturer Specific Status Word

Word layout used by specific manufacturers for information exchange. Defines Company ID in its Binary form.

Attachment 11 – System Address Labels

Chart relating avionic system to its Octal System Address Label

Appendix 1 – Laboratory Verification of ARINC429 DITS Electrical Characteristics

Summary of verification test procedures on the electrical characteristics of ARINC429.

Appendix 2 – An Approach to a Hybrid Broadcast-Command/Response Data Bus Architecture

An approach to interfacing an ARINC429 bus system with a MIL-STD-1553A bus. Prepared by the Information Engineering Division of the USAF Directorate of Avionics Engineering.

Appendix 3 – Digital Systems Guidance (Part 1)

Commentary on interfacing ARINC429 with digital data buses.

Appendix 4 – Digital Systems Guidance (Part 2)

Response to commentary on digital interface.

Appendix 5 – Guidelines for Label Assignments

Guidelines to be applied when assigning word labels not otherwise defined.

Appendix X – Chronology and Bibliography



ARINC CONTACT INFORMATION

A complete copy of the ARINC429 Specification can be obtained by contacting ARINC
at:

**Aeronautical Radio, Inc.
2551 River Road
Annapolis, MD 21401**

Or by visiting the ARINC website at:

www.arinc.com